

Chapter 5 Worksheet**Part 1: Multiple choices**

1. The atomic particle that carries a negative charge is called
 - A. **The electron**
 - B. The proton
 - C. The neutron
 - D. The atom
2. The atomic particle that carries a positive charge is called
 - A. The electron
 - B. The proton**
 - C. The neutron
 - D. The atom
3. The force between two like charges is
 - A. Attractive
 - B. Repulsive**
 - C. Both repulsive and attractive
 - D. There is no such force
4. By rubbing two objects we can charge
 - A. A Battery
 - B. A conductor
 - C. An insulator**
 - D. Both insulator and a conductor
5. The process by which a metal is charged when it is touched by a charged object is called
 - A. Static electricity
 - B. Polarization
 - C. Induction
 - D. Conduction**
6. The process by which a metal is charged when it comes near a charged object is called
 - A. Static electricity
 - B. Polarization
 - C. Induction**
 - D. Conduction
7. When two objects rubbed together like a comb and hair
 - A. Protons transfer from one to another
 - B. Atoms transfer from one to another
 - C. Electrons transfer from one to another**
 - D. Neutrons transfer from one to another
8. Which of the following is an insulator
 - A. Glass**
 - B. Copper
 - C. Aluminum
 - D. Water

9. When the distance between two charges is reduced into a half the force between them will be
- A. Reduced by a half
 - B. Reduced by a $\frac{1}{4}$
 - C. Doubled
 - D. Increased by four times
10. According to Ohm's law, the potential difference across a conductor (wire) of resistance R
- A. Creates current
 - B. Creates voltage
 - C. Creates resistance
 - D. All of the above

Part2: True/False. If the answer is false, then correct it.

1. Insulators allow the movement of free electrons inside them.
 - A. True
 - B. False
2. Insulators have free electrons and conductors do not.
 - A. True
 - B. False
3. Static electricity is the buildup of charge as result of friction between two objects.
 - A. True
 - B. False
4. The total (equivalent) resistance in a series circuit is given by the sum of the inverse of the individual resistances.
 - A. True
 - B. False
5. The total (equivalent) resistance in a parallel circuit is given by the sum of the sum of the individual resistances.
 - A. True
 - B. False
6. The current in a parallel circuits is give by the sum of currents in the branches.
 - A. True
 - B. False
7. Batteries supply AC current.
 - A. True
 - B. False
8. Conventional current is the flow of negaqtive charge from the positive terminal, to the connecting wire, and back to the negative terminal of a battery.
 - A. True
 - B. False
9. Watt is unit of electrical energy.
 - A. True
 - B. False
10. It is a kind of misleading writing Ohm's law as $V = IR$
 - A. True

B. False**Part3: Review questions.** Write your answers in your own notebook

1. What particles make up an atom? **electrons, protons and neutrons**
2. Where are the protons and neutrons are located? **Inside the nucleus**
3. What charge does the neutron have? **No charge**
4. The charge on electron is **negative** and the charge on the proton is **positive**
5. The unit of charge is **coulomb**. The unit of electrical current is **ampere**.
6. The unit of power is **watt**. The unit of potential difference is **volt**.
7. The instrument that measures current is called **ammeter**. The instrument that measures potential difference (voltage) is called **voltmeter**.
8. What is the relationship between power, current, and voltage? **$V = IR$**
9. Describe the process of charging an insulator by a negative charge.
10. Describe the process of charging an electroscope by conduction.
11. Describe an electric field.
12. Describe the relationship between electron current and conventional current.
13. In which way does an ammeter should be connected in a circuit? **series**
14. In which way does a voltmeter should be connected in a circuit? **parallel**
15. How does the current change in a circuit when the voltage is increased by factor 2? **double**
16. How does the current change in a circuit when the resistance increases by a factor 2? **half**
17. Describe Ohm's law.
18. Describe Coulomb's law.
19. Distinguish between series and parallel circuits.
20. Describe grounding.

Part4: exercises: solve problems in you own notebook.

1. Two charges of $-4\mu\text{C}$ each are 10cm apart. Find their interaction force. Is it repulsive or attractive? Explain.
2. The repulsive force between two identical charges is 20N when they are 6cm apart. Find the magnitude of each charge.
3. A charge of $250\mu\text{C}$ exerts a force of $2.50 \times 10^{-2}\text{N}$ on a second charge of $50\mu\text{C}$. How far apart are the charges?
4. A resistor is connected to 115V. If it receives 8.75 Amp, find its resistance.
5. Four resistors of 2Ω , 6Ω , 10Ω , and 3Ω are connected in series to 12 V battery. Find the total resistance of the circuit. Find also the current.
6. A heater coil receives 8.7 Amp from a 110 V line. Find the power.
7. How much current will a 60 watt lamp receives from a 110 V line?
8. A hand drill receives 4 amp and has a resistance of 15Ω . What power does it use?
9. 10 Coulombs of negative charge are transferred from object A to object B. What is the net charge on each object?
10. How many electrons are there in $10\mu\text{C}$ of charge?

11. Find the equivalent resistance between the points a and b of the combination of resistors shown below

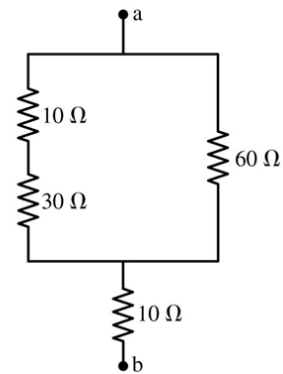

12. Find the current in exercise 9 when the points a and b are connected to a 12 V battery.
 13. Find the equivalent resistance of the two combination of resistors shown below.

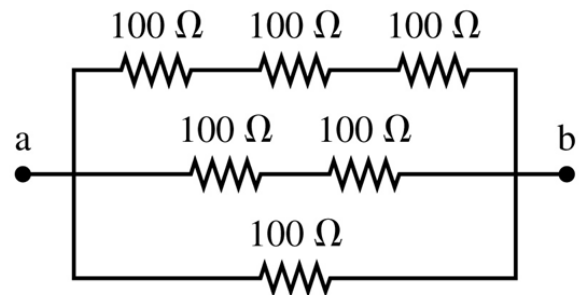
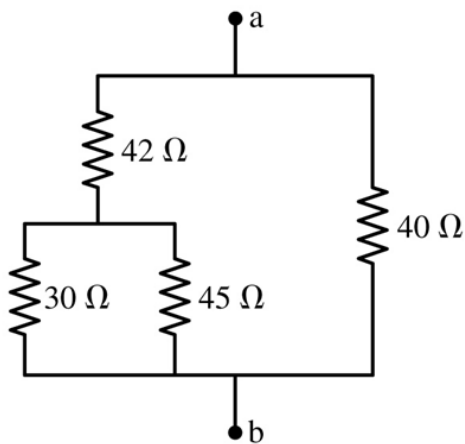

Part4: Describe what you see: In your own words, describe and explain the following observations

1. A plastic charged rod and a charged ball.

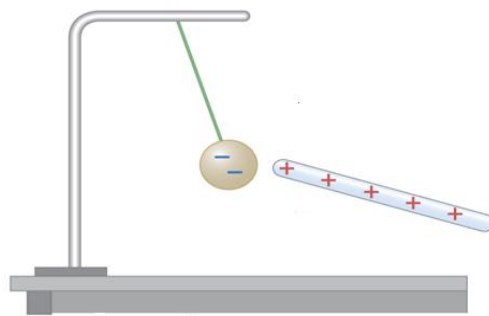
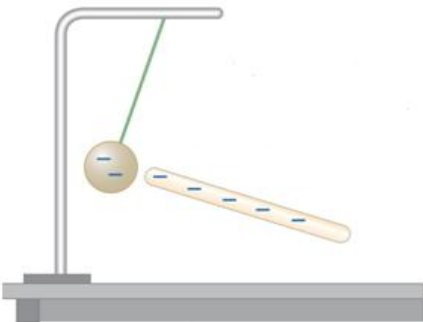

2. A comb and bits of paper



3. A charged object is brought close an insulator (wall)

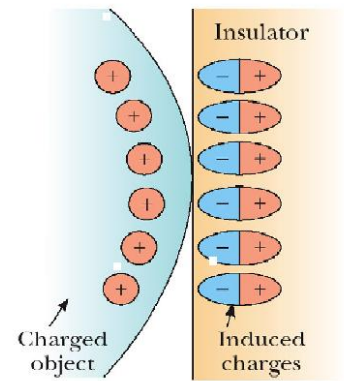

4. A neutral metal ball and a charged object

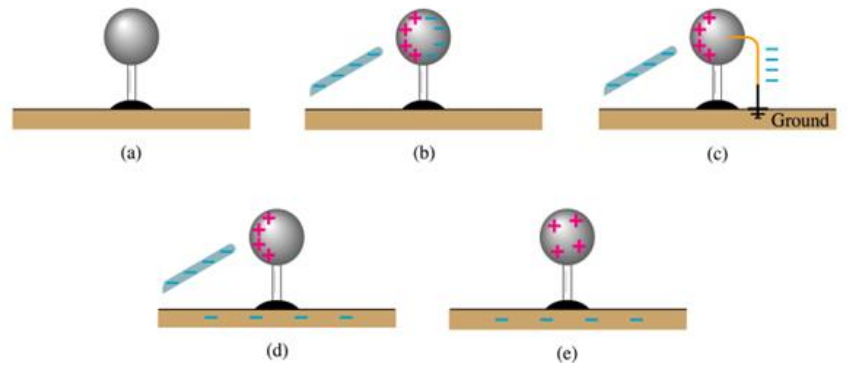

5. A man and ballons



Part5: Challenge problems

1. In the circuit shown below find (a) the equivalent resistance (b) the current in the circuit, and (c) the voltage on the resistor

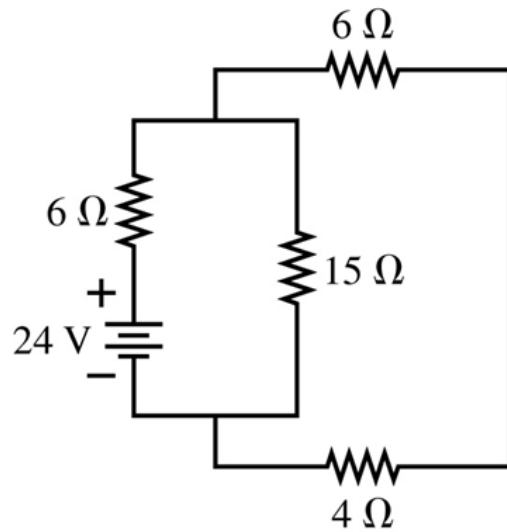

2. In the compound circuit shown below find (a) the current in the circuit and (b) the voltage on the resistance 4 Ω

